

LOC	DIST	REVISIONS					
AF	50	P	LTR	DESCRIPTION	DATE	DWN	APVD
			H1	REVISED PER ECR-14-013776	17SEP2014	NK	DC

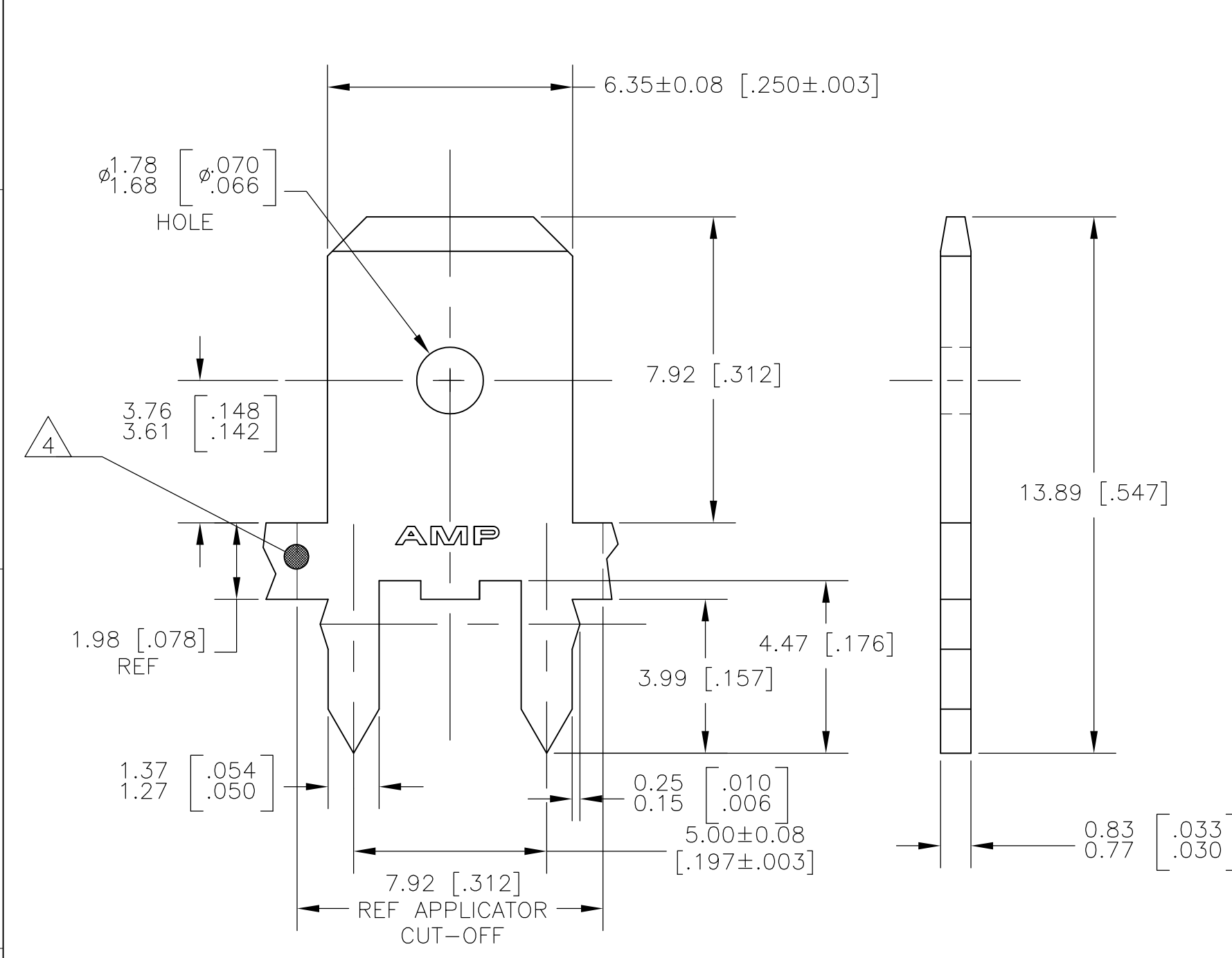

- 1 CONTINUOUS STRIP ON REELS.
- △ 2 TIN PLATE 0.00381 [.000150] MIN OVER 0.00254 [.000100] MIN THK COPPER OR TIN PLATE 0.00381 [.000150] MIN OVER 0.00127 [.000050] MIN THK NICKEL.
- 3 FEED IS 7.92±0.076 [.312±.003]
- △ 4 OPTIONAL ID MARK, LOCATION APPROX AS SHOWN.
- △ 5 REELED WITH INTERLEAVING PAPER.

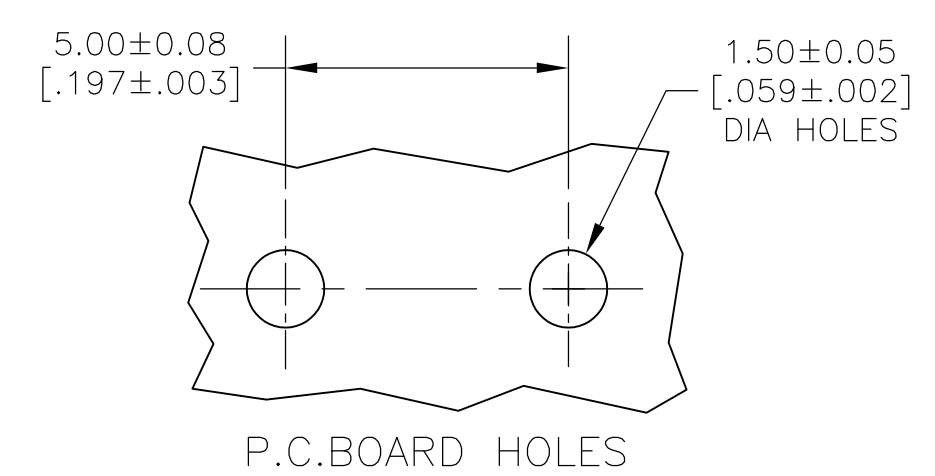

△ 5	63986-3
	63986-1
PART NUMBER	

THIS DRAWING IS A CONTROLLED DOCUMENT.		DWN	JR RUTH	30NOV00	TE Connectivity					
DIMENSIONS: mm[INCHES]		CHK	MS FEHER	30NOV00						
TOLERANCES UNLESS OTHERWISE SPECIFIED:		APVD	G PORTA	30NOV00						
0 PLC ± - 1 PLC ± - 2 PLC ± 0.25 [.010] 3 PLC ± - 4 PLC ± - ANGLES ± -		PRODUCT SPEC	-							
MATERIAL	BRASS	FINISH	△ 2		NAME	TAB, FASTON, PC BOARD, 6.35 [.250] SERIES				
		APPLICATION SPEC	114-2115		SIZE	A3	CAGE CODE	00779		
		WEIGHT	-		DRAWING NO	C-63986		RESTRICTED TO	-	
CUSTOMER DRAWING					SCALE	8:1	SHEET	1 OF 1	REV	H1